

Model-OM17000					
Gear ratio	348	Turns to close	87	Bore dia (max.)	113mm
Rated output torque	17000Nm	Rated input torque	162Nm	Stem bore depth (max.)	165mm
Mechanical advantage	105	Mounting base ISO 5211	F25,F30	Unit weight	145Kg

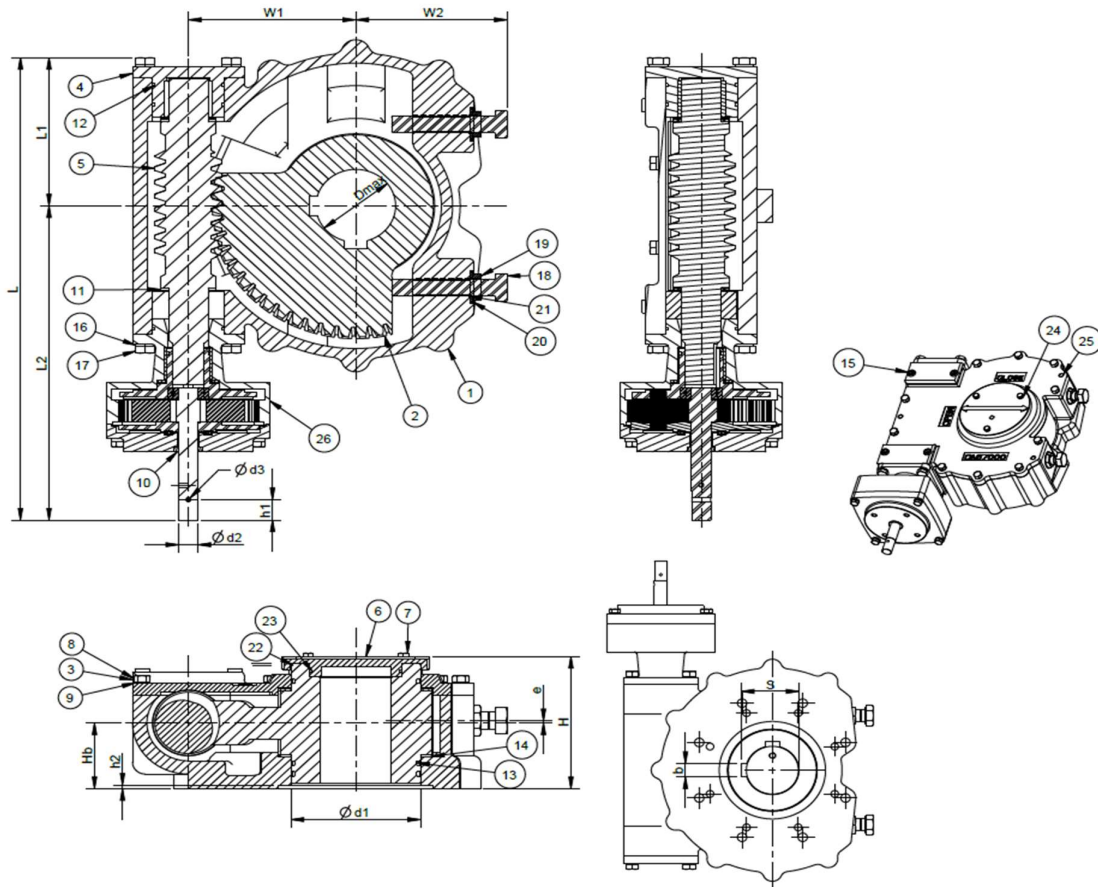

MODEL	L	L1	L2	W1	W2	H	Hb	e	ØDmax	s ^{+0.2}	b	Ød1	h1	Ød2	h2	Ød3	ISO
OM17000	635	203.5	431.5	210	180	181	90	3	113	120.4	28.15 28.07	168.5 168.4	28	23.90 23.84	5	6	F25,F30

Item	Description	Qty	Material / Standard
1	Housing	1	SG Iron IS:1865 400/15
2	Quadrant	1	SG Iron IS:1865 500/7
3	Top cover	1	SG Iron IS:1865 400/15
4	End cover rear	1	SG Iron IS:1865 400/15
5	Worm shaft	1	BS:970 709M40 COND.R
6	Indicator	1	Aluminium
7	Hex Head screws	3	IS:1367 Gr.8.8
8	Hex Head screws	10	IS:1367 Gr.8.8
9	Spring Washer	10	Carbon Steel
10	Oil seal	1	Nitrile rubber
11	Taper roller bearing	2	Stainless steel - 316
12	O Ring-Rear cover	3	Nitrile rubber - 70 Shore
13	O Ring-Quadrant	3	Nitrile rubber - 70 Shore

Item	Description	Qty	Material / Standard
14	Thrust washer	2	Stainless steel – 316
15	Socket head screw	4	ISO-4762
16	Hex Head screws	8	IS:1367 Gr.8.8
17	Hex Head screws	8	IS:1367 Gr.8.8
18	Hex Head Bolt	2	IS:1367 Gr.8.8
19	Hex thin nut	2	IS:1367 Gr.8.8
20	Copper washer	2	IS:1367 Gr.8.8
21	O Ring	2	Nitrile rubber - 70 Shore
22	Indicator-Gasket	1	Nitrile rubber - 70 Shore
23	O Ring-Indicator	2	Nitrile rubber - 70 Shore
24	Plain washer	3	Carbon Steel
25	Dowel	4	SS
26	PG-Assembly	1	SG Iron IS:1865 400/15